

Mixer Connections

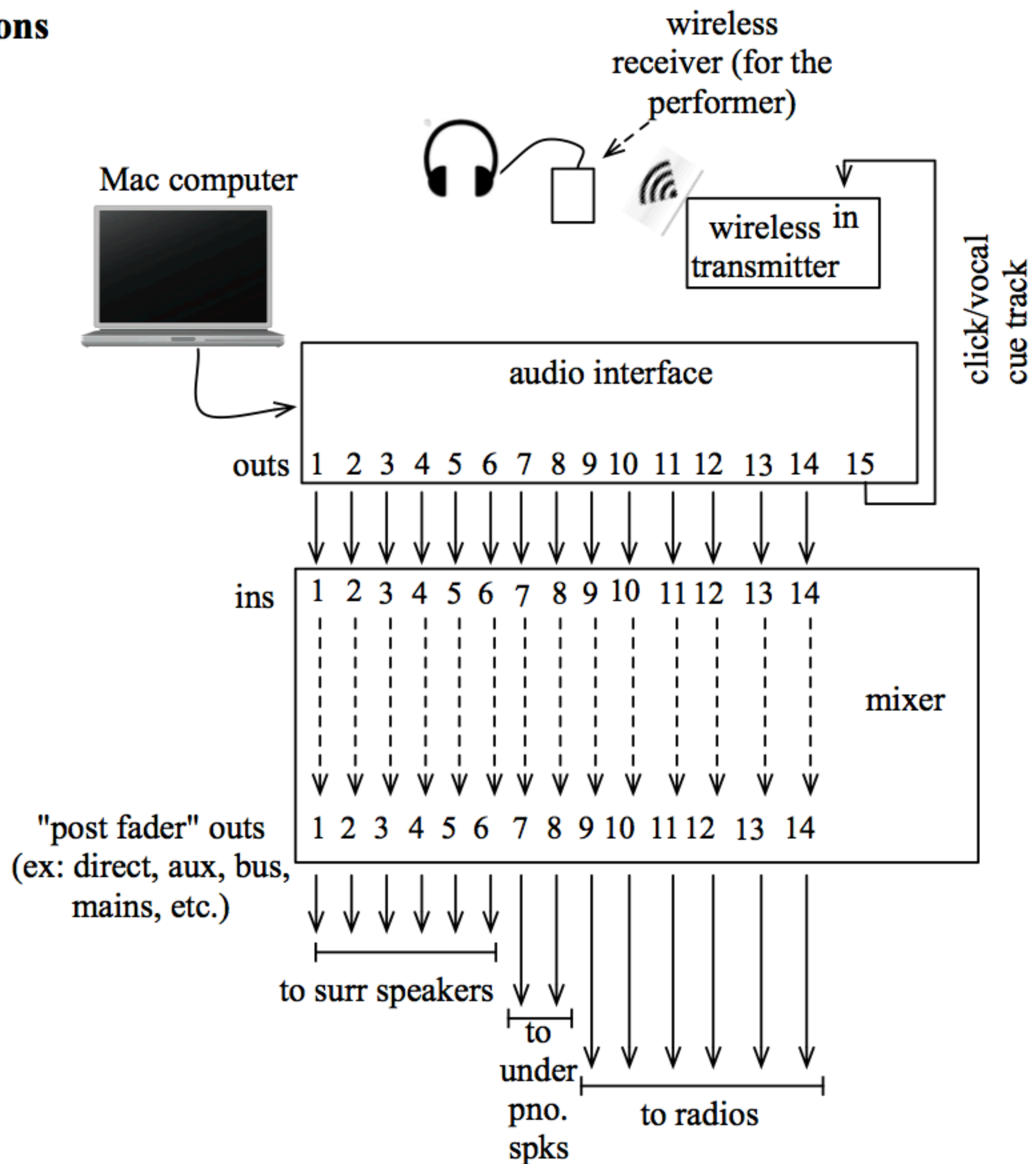

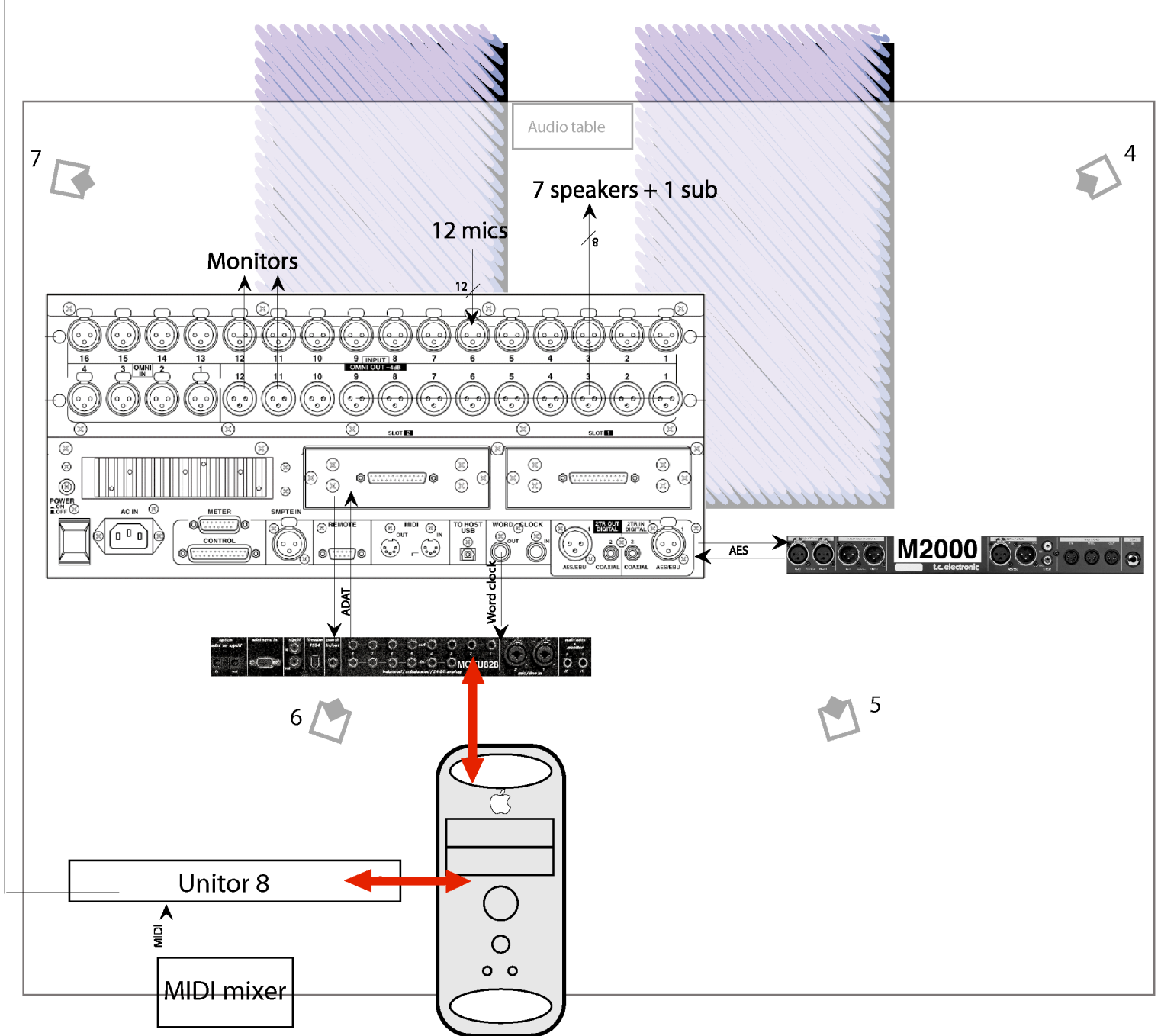
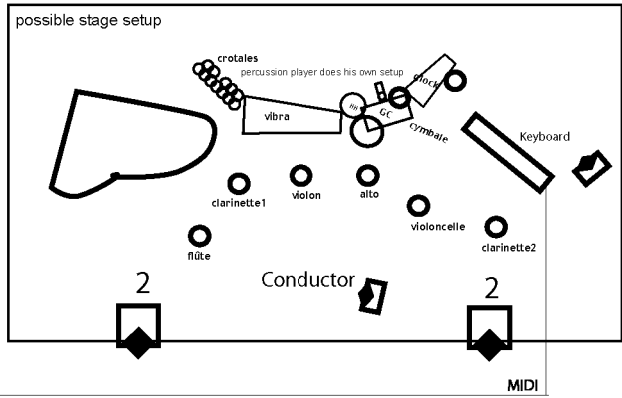

Legend:

- Speaker
- Sub
- Monitor
- Microphone
- Public
- Computer

Amok Koma
 Fausto Romitelli
 octobre 2004

Schéma audio et Midi

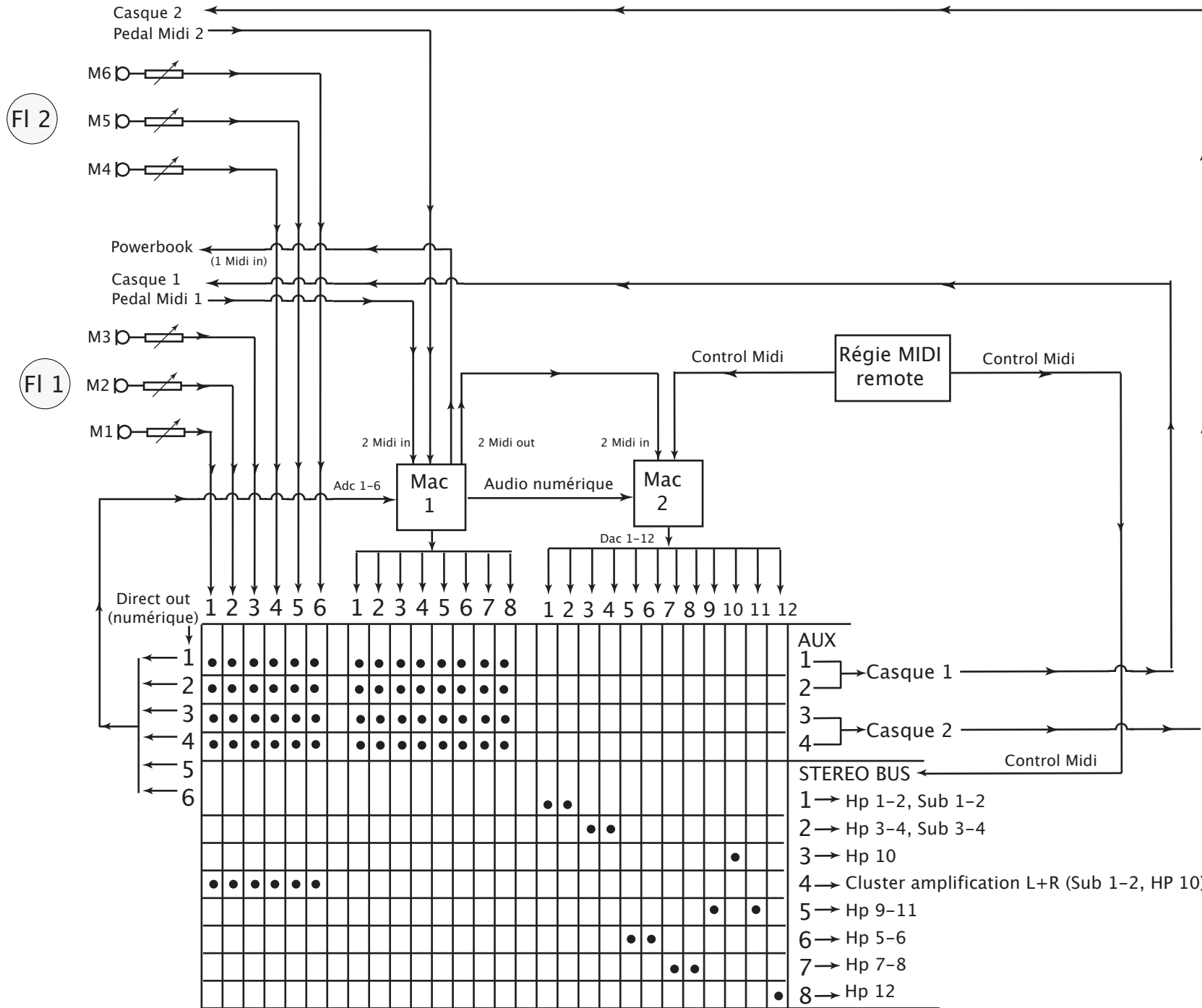

REGIE REMOTE

AUDIO

- 4 Niveaux:
- Plancher (1-2)
- Centre (3-5)
- Cluster amplification (4)
- Plafond (6-7-8)

MIDI

- 1 Niveau reverb
- (ou room control, Spat Oper)

Table de mixage: Groupes

PLANCHER

- 1 Hp 1-2, Sub 1-2
- 2 Hp 3-4, Sub 3-4

CENTRE

- 3 Hp 10
- 4 Cluster amplification L+R
- 5 Hp 9-11

PLAFOND

- 6 Hp 5-6
- 7 Hp 7-8
- 8 Hp 12

- AUX
- 1 → Casque 1
- 2 → Casque 2
- STEREO BUS
- 1 → Hp 1-2, Sub 1-2
- 2 → Hp 3-4, Sub 3-4
- 3 → Hp 10
- 4 → Cluster amplification L+R (Sub 1-2, HP 10)
- 5 → Hp 9-11
- 6 → Hp 5-6
- 7 → Hp 7-8
- 8 → Hp 12

Schéma audio et Midi de *Joy*

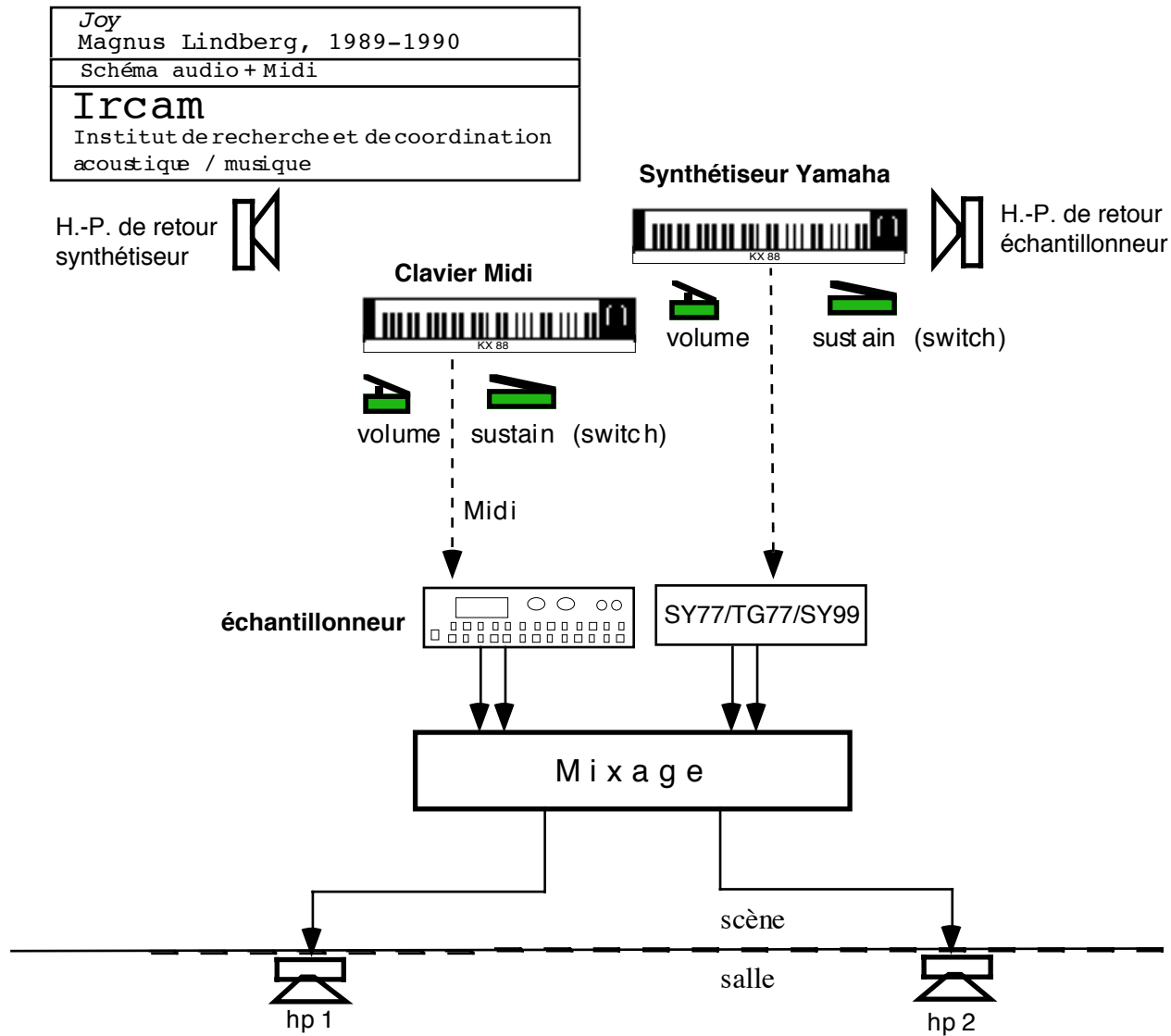

P. Leroux
Voix Rex

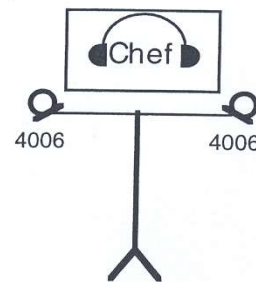
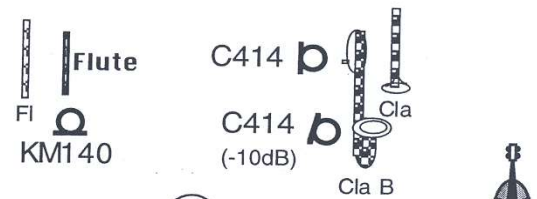
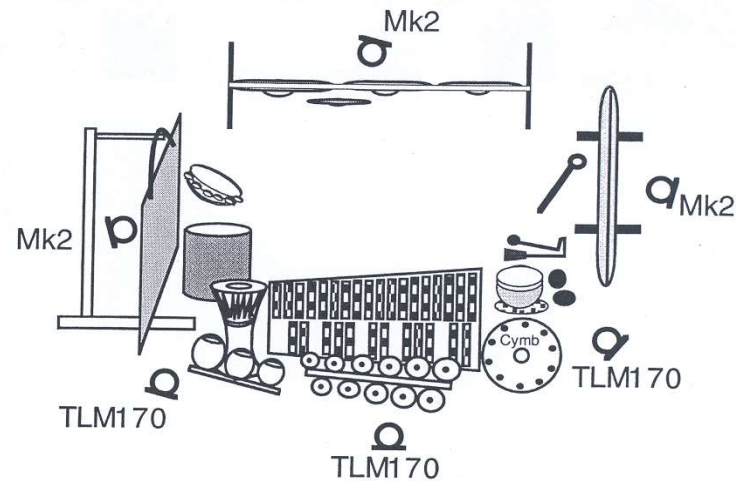

Figure 1. Installation diagram